



FITTING INSTRUCTIONS

Part Number: 3946020 **F/KIT:** 6173186

Product Description: COMBINATION SAHARA BAR FLARED

Suited to vehicle/s: MITSUBISHI TRITON 2009 ON

Buffer Kit: 5100020 (Sahara Bar), 5100030 (Sahara Bumper)

Centre Frame: 5146010 (Polished Centre Frame)

WARNING

REGARDING VEHICLES EQUIPPED WITH SRS AIRBAG:

When installed in accordance with these instructions, the front protection bar does not affect operation of the SRS airbag.

ALSO, NOTE THE FOLLOWING:

- ◆ This product must be installed exactly as per these instructions using only the hardware supplied.
- ◆ In the event of damage to any bull bar component, contact you're nearest authorised ARB stockist. Repairs or modifications to the impact absorption system must not be attempted.
- ◆ Do not use this product for any vehicle make or model, other than those specified by ARB.
- ◆ Do not remove labels from this bull bar.
- ◆ This product or its fixing must not be modified in any way.
- ◆ The installation of this product may require the use of specialized tools and/or techniques
- ◆ It is recommended that this product is only installed by trained personnel
- ◆ These instructions are correct as at the publication date. ARB Corporation Ltd. cannot be held responsible for the impact of any changes subsequently made by the vehicle manufacturer
- ◆ During installation, it is the duty of the installer to check correct operation/clearances of all components
- ◆ Work safely at all times
- ◆ Unless otherwise instructed, tighten fasteners to specified torque

ARB 4x4 ACCESSORIES

Corporate Head Office

42-44 Garden St
Kilsyth, Victoria
AUSTRALIA 3137

Tel: +61 (3) 9761 6622
Fax: +61 (3) 9761 6807

Australian enquiries
North & South American enquiries
Other international enquiries

sales@arb.com.au
sales@arb.com.au
exports@arb.com.au

www.arb.com.au

GENERAL CARE AND MAINTENANCE



By choosing an ARB Bar, you have bought a product that is one of the most sought after 4WD products in the world. Your bar is a properly engineered, reliable, quality accessory that represents excellent value. To keep your bar in original condition it is important to care and maintain it following these recommendations.

- Prior to exposure to the weather your bar should be treated to a Canuba based polish on all exposed surfaces. It is recommended that this is performed on a six monthly basis or following exposure to salt, mud, sand or other contaminants.
- As part of any Pre Trip Preparation, or on an annual basis, it is recommended that a thorough visual inspection of the bar is carried out, making sure that all bolts and other components are torqued to the correct specification. Also check that all wiring sheaths, connectors, and fittings are free of damage. Replace any components as necessary.
- Please contact local Authorised ARB Stockist if you would like to have this service carried out on your behalf.

HAVE AVAILABLE THESE TOOLS WHEN FITTING PRODUCT:

BASIC TOOL KIT	JIG SAW OR KEY HOLE SAW
MASKING TAPE	STEEL RULE 300mm
MARKING PEN	POWER DRILL AND DRILL BIT SET

HAVE AVAILABLE THESE SAFETY ITEMS WHEN FITTING PRODUCT:

Protective eyewear 	Hearing protection 
--	--

NOTE: 'WARNING' notes in the fitting procedure relate to OHS situations, where to avoid a potentially hazardous situation it is suggested that protective safety gear be worn or a safe work procedure be employed. If these notes and warnings are not heeded, injury may result.

FASTENER TORQUE SETTINGS:

SIZE	Torque Nm	Torque lbft
M6	9Nm	7lbft
M8	22Nm	16lbft
M10	44Nm	32lbft
M12	77Nm	57lbft

USE	PART No	QTY	DESCRIPTION
IMPACT ABSORBER MOUNTING SYSTEM	6151357	7	BOLT M10 x 1.5 x 30mm SEMS ASSY
	6151090	2	BOLT M10 X 1.25 X 50mm
	6151040	1	BOLT M10 X 1.25 X 30mm
	4581040	1	WASHER FLAT M10
	4581048	3	WASHER SPRING M10
	4584291	2	WASHER CLAMPING
	3758945	1	MOUNT ASSEMBLY
	5848329	2	PACKER LOCATING
	6151321	7	NUT M10 FLANGE
	6151021	2	BOLT M8 X 20mm
	4581044	2	WASHER FLAT M8
	4581046	2	WASHER SPRING M8
BULL BAR TO IMPACT ABSORBERS	6151132	2	NUT FLANGE M8
	3756929 L/R	2	BRKT REAR EXTENSION BRACE
	6151357	8	BOLT M10 x 30mm SEMS ASSY
	6151360	6	BOLT M12 X 1.75 X 35 COARSE PITCH
	4581007	6	WASHER FLAT M12 X 37 X 4
	4581050	6	WASHER SPRING M12
	6151428	6	NUT FLANGE M12
	6151321	8	NUT FLANGE M10 X 1.5
	3788074	1	TEMPLATE TO CUT FRONT BUMPER
	4681395	L/R	BRACE WING SAHARA
	6151021	8	BOLT M8 X 20mm
	4581044	8	WASHER FLAT M8
4581046	8	WASHER SPRING M8	
6151132	8	NUT FLANGE M8	
3194353	2	PACKER PLATE	
CONTROL BOX BRACKET	6151021	2	BOLT M8 x 20mm
	4581044	2	WASHER FLAT M8
	3751564	1	CONTROL BOX BRACKET
	6151132	2	NUT FLANGE M8
NUMBER PLATE BRACKET	6151180	4	BOLT M6 x 20mm (BRACKET TO BAR)
	6151046	4	WASHER FLAT M6 x 13mm
	6151128	4	NUT FLANGE M6
	3751313	1	NUMBER PLATE BRACKET
	6151384	2	SCREW PAN HD (NON WINCH BAR)
	6821189	2	GROMMET RHS
INDICATORS TO BAR	3163015	1	LIGHT INSERT KIT
	6821151L	1	OS LIGHT INDICATOR LHS
	6821151R	1	OS LIGHT INDICATOR RHS
	6821152	2	TURN SIGNAL / CLEARANCE LIGHT LOOM
	180701	6	SCOTCH LOK
CENTRE FRAME TO BAR	6151255	2	BOLT M12 X 1.75 X 40
	4581049	2	WASHER FLAT M12
	4581050	2	WASHER SPRING M12
PANEL WINCH COVER	6522690	1	PANEL WINCH COVER
	6151256	2	SCREW M6 BUTTON HEAD S/S
	4581304	2	WASHER M6 S/S
	6151128	2	NUT FLANGE M6
	6191006	1	EXTRUSION WINCH COVER
WINCH FITMENT	BLB 600	1	BATTERY LEAD 600MM BLACK
	180302	8	CABLE TIES
	6151073	2	BOLT 3/8" X 1 1/2"
	6151074	2	BOLT 3/8" X 1 3/4"
	4581040	4	WASHER FLAT M10
	EG50	2	GROMMET RUBBER

USE	PART No	QTY	DESCRIPTION
BUFFERS	6151128	12	NUT FLANGE M6
AIR DEFLECTOR	6522664	1	AIR DEFLECTOR
	6151262	3	BOLT M8 X 20mm BLACK
	6151301	3	NUT CAGED M8
	4581045	3	WASHER FLAT M8 x 20mm BLACK
	4581047	3	WASHER SPRING M8 BLACK
	6151213	4	BOLT M6 X 20MM BLACK
	4581082	4	WASHER FLAT M6
	4581287	4	WASHER SPRING M6
	6151300	4	NUT CAGED M6
UNDER WING PANEL	6151213	8	BOLT M6 x 20mm BLACK
	4581082	8	WASHER FLAT M6 BLACK
	4581287	8	WASHER SPRING M6 BLACK
	6151300	8	NUT CAGED M6
	6151301	4	NUT CAGED M8
	6151262	4	BOLT M8 X 20MM BLACK
	4581045	4	WASHER FLAT M8 BLACK
	4581047	4	WASHER SPRING M8 BLACK
	3758191	2	BRACKET ADJUSTABLE WING UNDER PANEL
	6522843L	1	WING UNDERPANEL LHS
	6522843R	1	WING UNDERPANEL RHS
MISCELLANEOUS	6191015	2	PLASTIC MOULDING
	3162152	2	PLUG PLASTIC 16MM DIA
BUFFER KIT BAR (5100020)	3162469 L/R	2	BUFFER 260 X 230 UPRIGHT B/BAR
BUFFER KIT BUMPER (5100030)	3162466 L/R	2	BUFFER 206 X 230 BUMPER BAR
CENTRE FRAME (5146010)	6131532	1	FRAME CENTRE ASSEMBLY

SHADED AREAS INDICATE ADDITIONAL KITS REQUIRED DEPENDENT ON SAHARA BAR/BUMPER SELECTION

TO FIT OPTIONAL FOG LIGHTS TO BAR, USE KIT NO. 6821201 AND WIRING HARNESS PART NO. 3500440

ASSEMBLY SEQUENCE FOR BULL BAR INSTALLATION.

PLEASE READ AND UNDERSTAND FITTING INSTRUCTIONS BEFORE ATTEMPTING TO FIT BAR TO VEHICLE



**Note: To fit a bar to the vehicle, the plastic bumper, grill panel has to be cut. The bumper will be cut later.
Refer to step 6.**

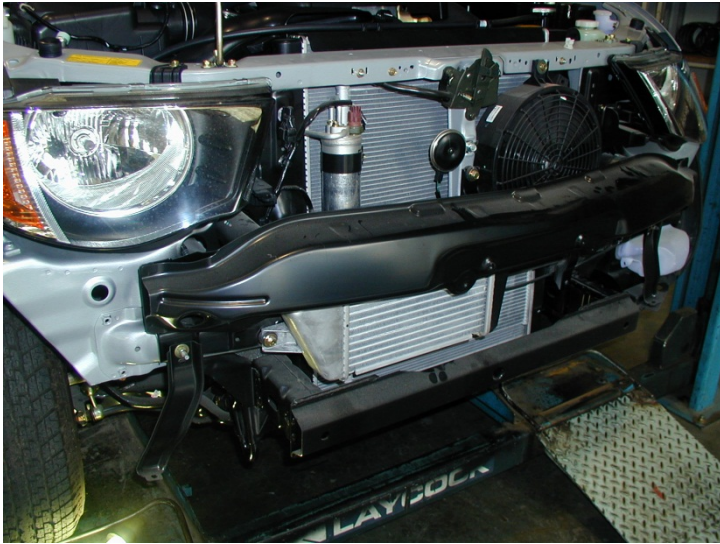

1. Remove grill and plastic bumper panel from front of vehicle.
2. When removing bumper, you will have to unclip flares half way back towards rear of vehicle.
3. Remove factory Stone Shield and retain with bolts.



4. Remove flare/bumper bracket from vehicle.

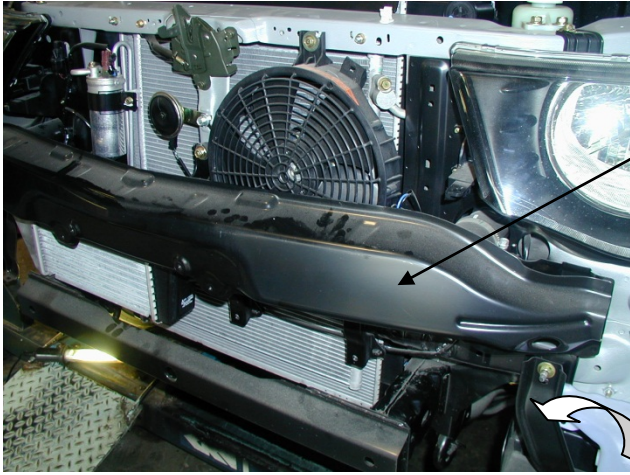

5. Remove cross member and mounting brackets from vehicle.

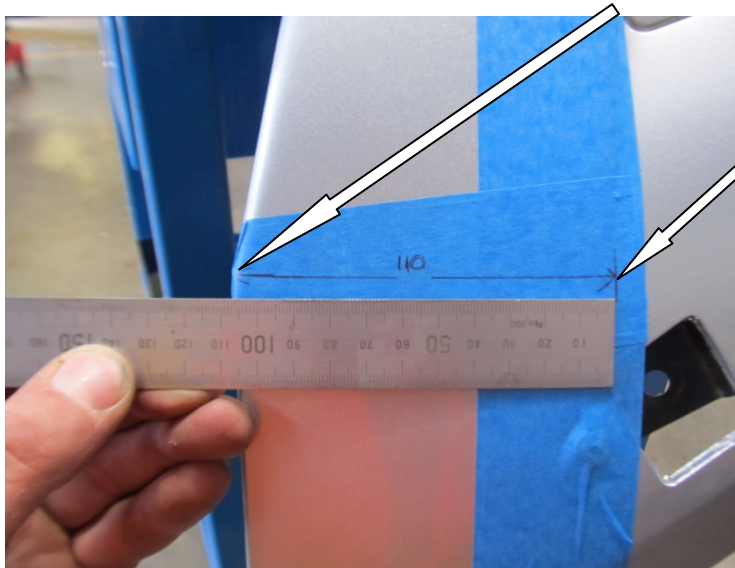

Bumper Bar Cut

6. Apply masking tape, measure and mark a point 110mm down from indicator corner point on Bumper.
7. Apply Masking tape, measure and mark point 10mm down from the centre of the License Plate landing.
8. Using Masking Tape starting at outside marked point, create a line to join the three points with the edge of the tape (which will become the cutting edge).

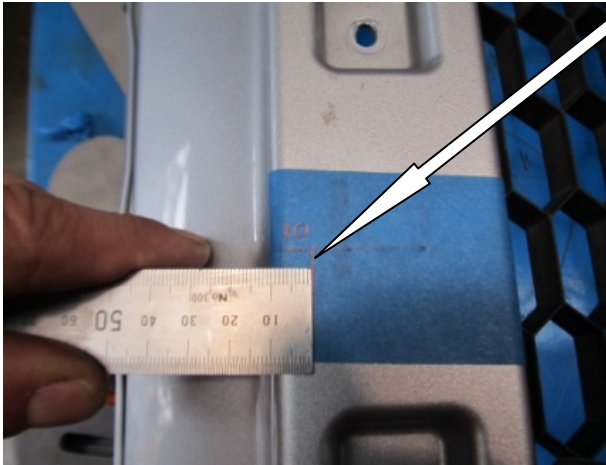

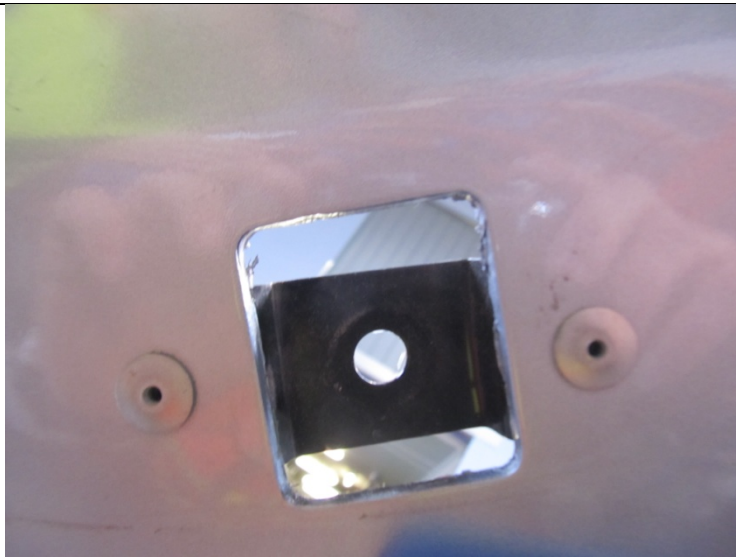

9. Remove metal Bumper Support Brackets by drilling out the rivets.



10. Apply another strip of Tape opposite to protect the Bumper whilst cutting.
11. Using a small Handsaw or Jigsaw cut along marked line from one side to the other. De bur sharp edges and remove tape.



12. Refit bumper back to vehicle and secure using originals fittings.
13. At this stage it is time to cut the lower section of the flares.
14. Temporarily refit front of flare back to front of vehicle.
15. Using the template supplied in the bolt kit fit to vehicle as per photo and secure using tape.
16. Draw a line to cut, and then remove the template and mark out the other side.



17. Lift flare away from vehicle, and cut along the drawn line, follow the same procedure on the other side.



18. Once the flares have been cut, clean up the edge with a file.



19. Mark out and cut off bumper panel under the flare.
20. Follow the flare line down as per photo and under bottom of flare.



21. Lift flare away from guard and cut out marked section.



22. Clean up the cut edge with a file and refit the flare.



23. Before cutting the LHS of vehicle, temporarily remove the washer bottle to enable the cutting of the lower section of the guard panel. Refit flare and washer bottle after cutting.





24. The vehicle is ready to fit the impact absorber mounting assembly.

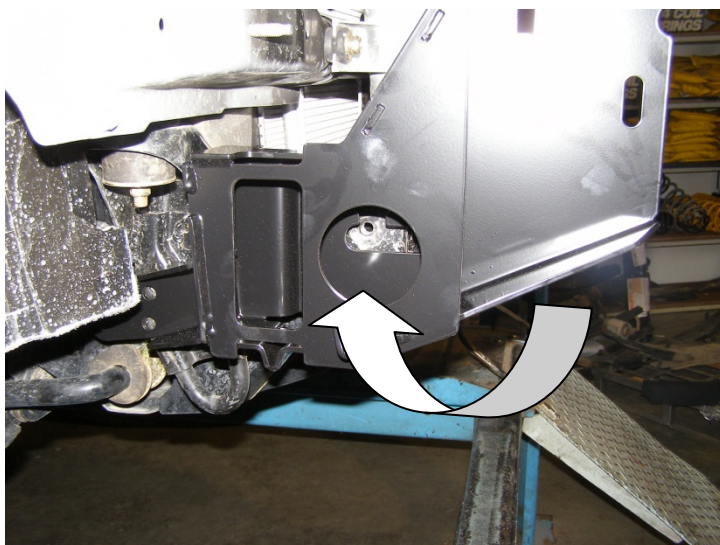

25. Fit impact absorber mounting assembly to vehicle chassis.

VIEW FROM RHS

10MM CAPTIVE NUT IN CHASSIS

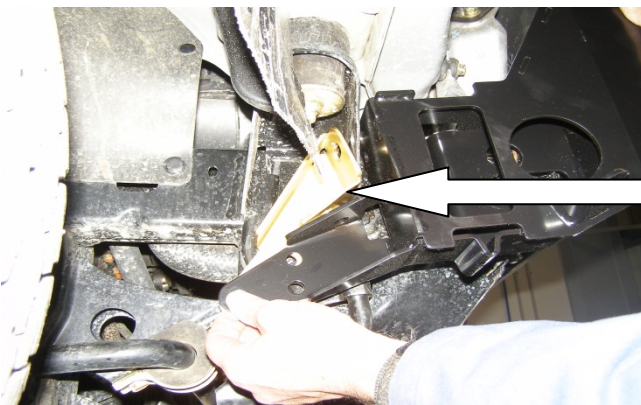

26. Before fastening impact absorber to vehicle, fit rear brace in between impact absorber and chassis and align rear holes with vehicle chassis holes.

27. **RHS** has a 10mm x 1.25 (fine thread) captive nut. Use top hole. Secure using a 10mm x 1.25 x 30mm Bolt, Spring washer and a 10mm flat washer.

Leave finger tight.

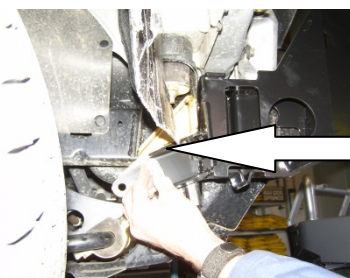

FITTING 10MM X 1.25 X 30MM BOLT



28. **LHS** side has a hole only, where a 10mm x 1.5 X 30mm SEMS bolt is fitted and secured by a 10mm flange nut.

FINGER TIGHTEN

SEMS BOLT & FLANGE NUT

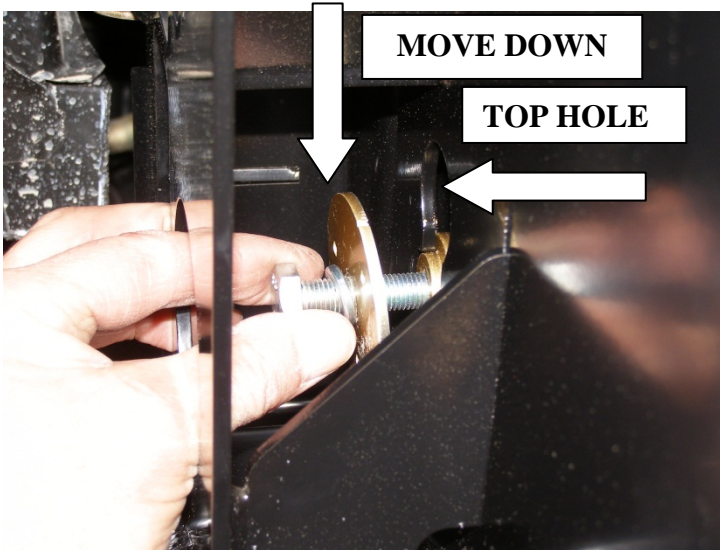

29. Using M10 x 1.25 x 50 mm bolt, 10mm spring washer, large flat washer and packer, feed into top hole and move down and screw bolt into captive nut in chassis. **FINGER TIGHTEN ONLY**

VIEWED FROM RHS

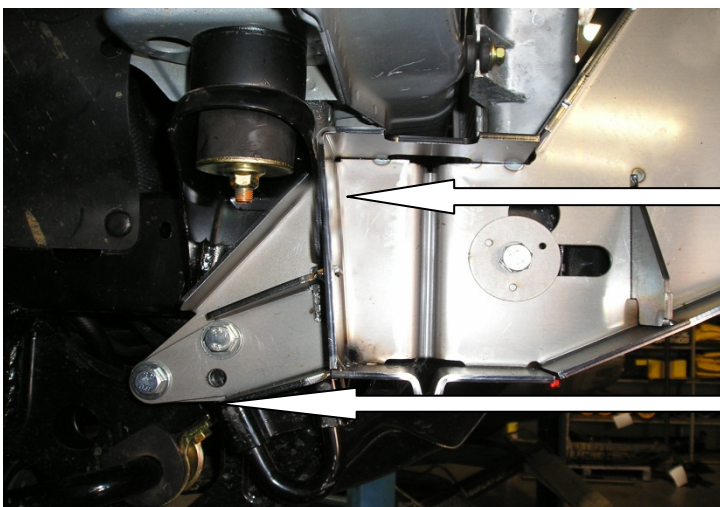

30. With the side and rear bolts fitted, fit the most rearward bolts to each side of the vehicle. Tighten all six bolts to specified torque.

NB. Before tightening, make sure that the two flanges are touching the body mount.

MOST REARWARD BOLT RHS

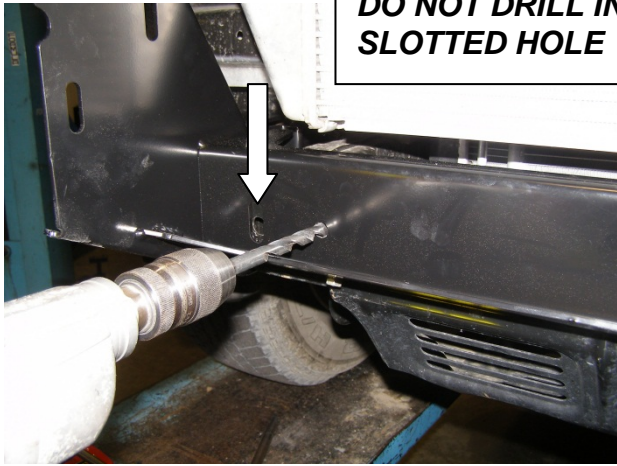

DO NOT DRILL IN SLOTTED HOLE

- 31. Using a Ø10mm drill bit, drill holes through chassis cross member, using holes in mount as a template.
- 32. Secure using 10mm X 30mm SEMS bolts, 10mm flange nuts. When the two bolts are fitted, tighten to specified torque.



- 33. Using a long Ø10mm drill bit, drill through vehicle body mount using hole in mount as a template, secure using 10mm X 30mm SEMS bolt, 10mm flange nut. When both sides of vehicle are done, tighten to specified torque.

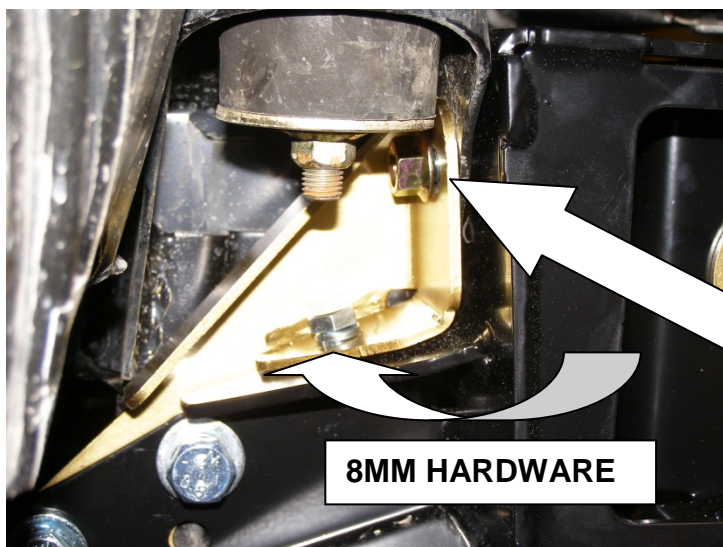

8MM HARDWARE

- 34. Fit M8 x 20mm bolt, spring washer, flat washer and 8mm flange nut to mounting assembly and tighten to specified torque.

USE BRIGHT ZINC M8 HARDWARE

SEE PHOTO STEP 26

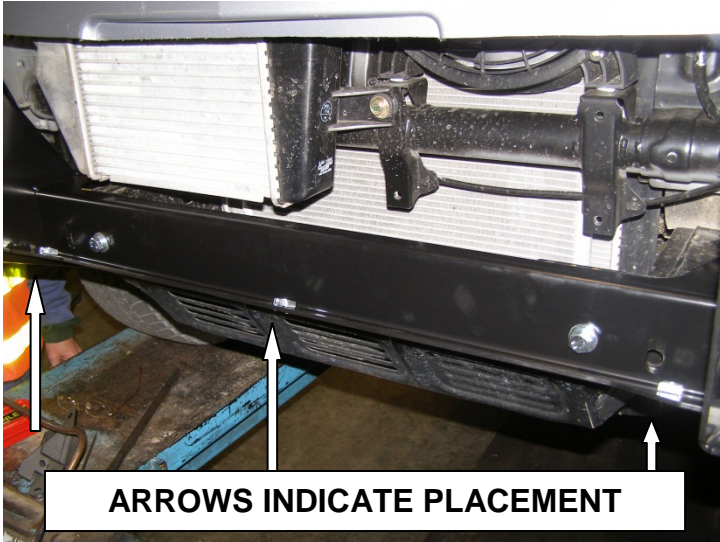

35. When impact absorber is securely bolted to vehicle, fit 8mm caged nuts to mounting assembly.

SEE PHOTOS FOR PLACEMENT OF CAGED NUTS, 5 IN TOTAL.



36. The next step is to fit the buffers to the bar using 6mm flange nuts, 6 per side. (DO NOT OVER TIGHTEN)

37. Fit 6mm caged nuts into lower flange of centre section of bar, 3 in total.

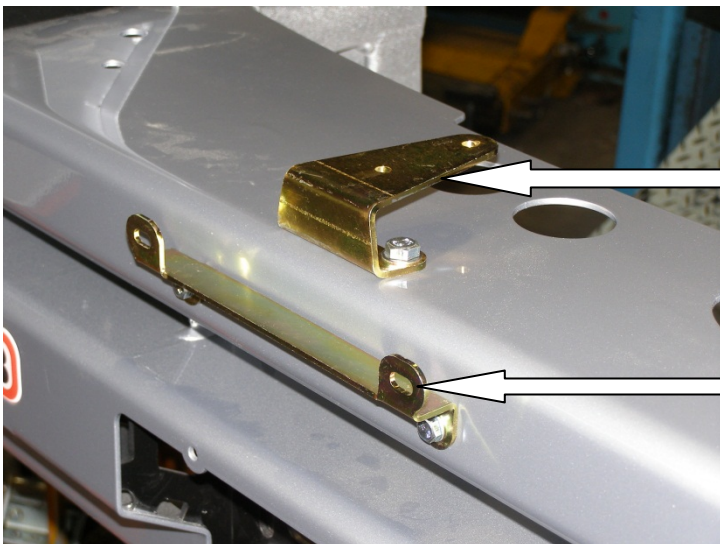

If you are not going to fit a winch to the bar, go to step 51

38. If a winch is to be fitted to the bar, fit control box bracket to bar using 8mm hardware. Next fit number plate bracket to bar using 6mm hardware.

IN BOTH CASES USE BRIGHT ZINC PLATED HARDWARE.

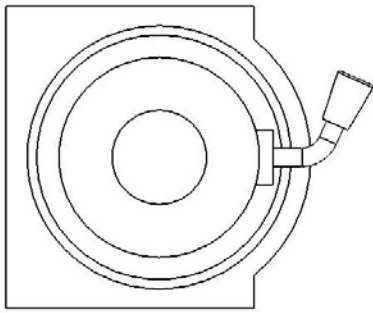

ORIGINAL

**VIEWED FROM
LHS OF
VEHICLE**

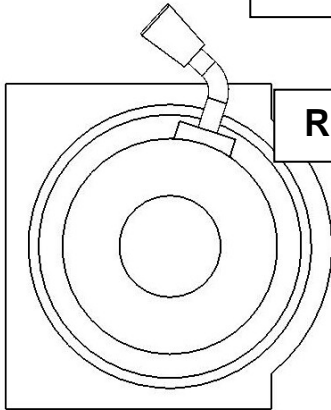

ROTATED

TO FIT A WINCH BAR

39. To fit an 8/9/9.5/000lb winch, rotate gearbox 72° counter clockwise.

Stand winch upright and undo the capped head screws and by lifting the gearbox only a couple of millimetres, rotate the gearbox. Once in position, refit all screws and tighten firmly.

WARNING: Do not lift gearbox more than a couple of millimetres.

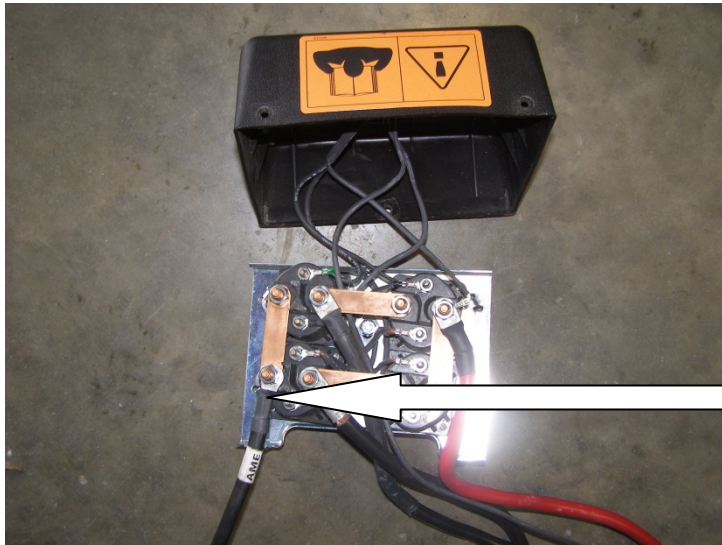

40. To fit control box to bar, you must change the lead (yellow tagged) in photo with the longer lead that is supplied in fitting kit. When all is fitted, screw plastic cover back onto control box.



41. To fit winch into bar you must pack winch up on a bench to enable you to lower bar down on winch, then fit four 3/8" square nuts into winch lugs .

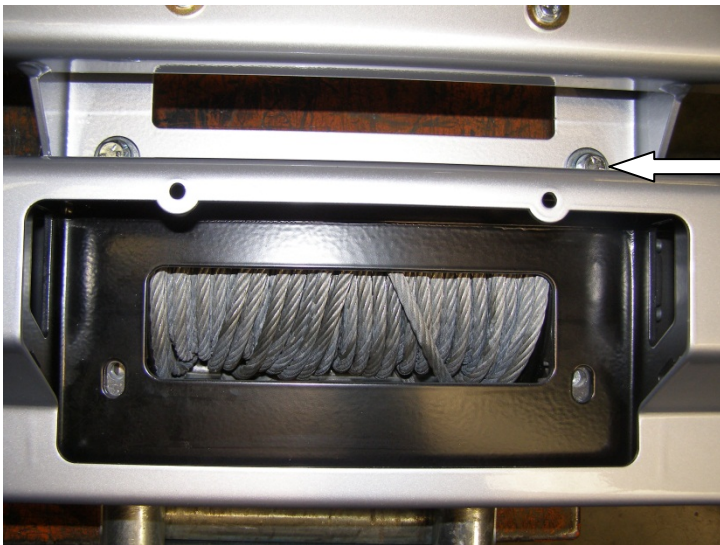

42. Lower bar down over winch, line up top holes first and secure using 3/8" hardware (1 1/2" x 3/8"bolts) flat and spring washers. (***finger tighten only***)

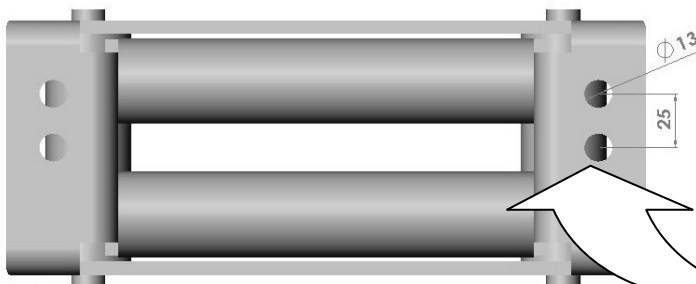

43. Drill two new Ø13mm holes in the roller fairlead provided in the kit, as shown on the adjacent picture.

Use new drill holes to bolt to bar.

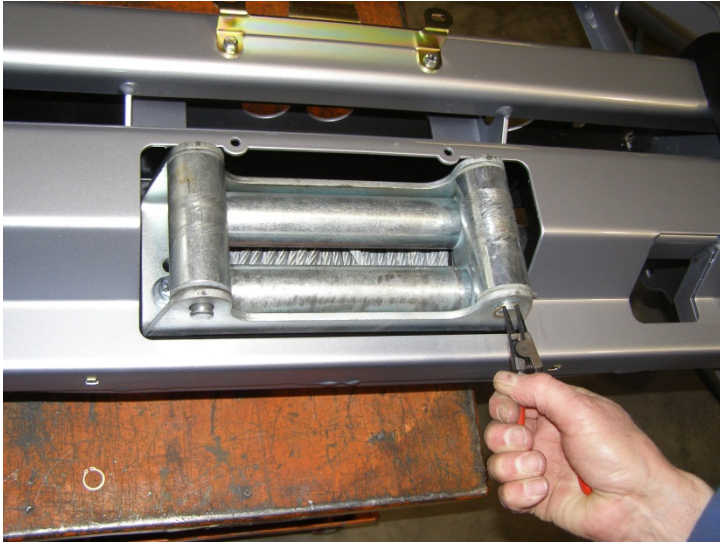

44. Place roller fairlead over lower holes and again secure using 3/8" hardware (1 3/4"x 3/8" bolts) flat and spring washers.
45. Using circlip pliers remove lower circlips and push shaft upwards to enable rollers to move sideways to access bolt holes.



46. Using screwdriver move vertical rollers sideways and tighten all bolts using socket and extension.
47. Refit rollers and circlips.

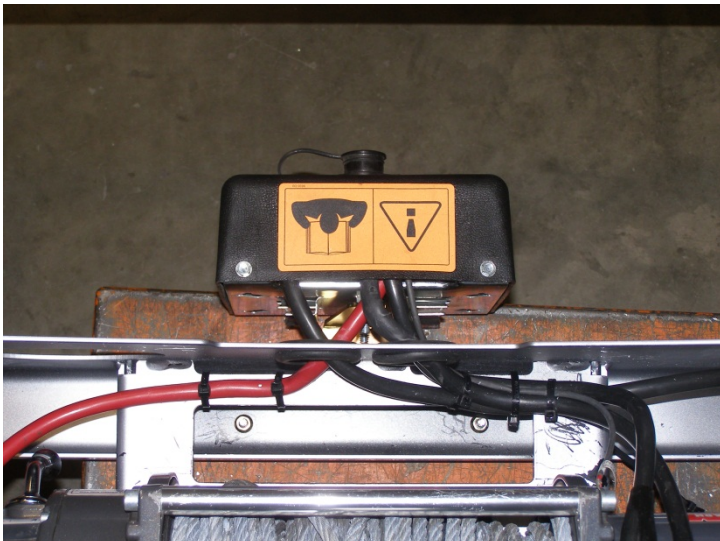
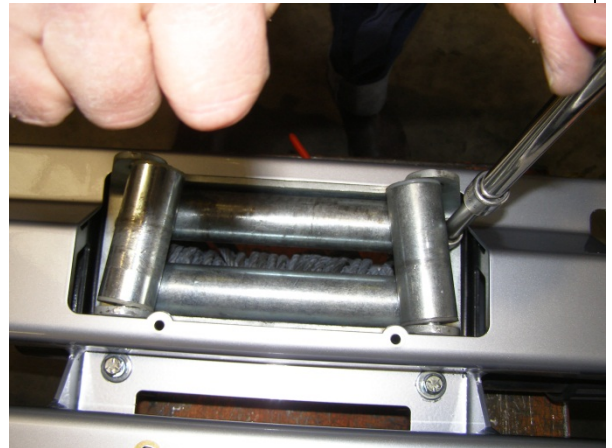

48. Fit rubber grommets into round holes in top of bar, then fit control box to control box bracket and pass cables through rubber grommets.



49. Fit all 3 cables to their correct terminals and tighten. Refer to Warn installation instruction when wiring up winch. Fit plastic boots over terminals. Cable tie cables to bar as per photo to clear of all moving parts.

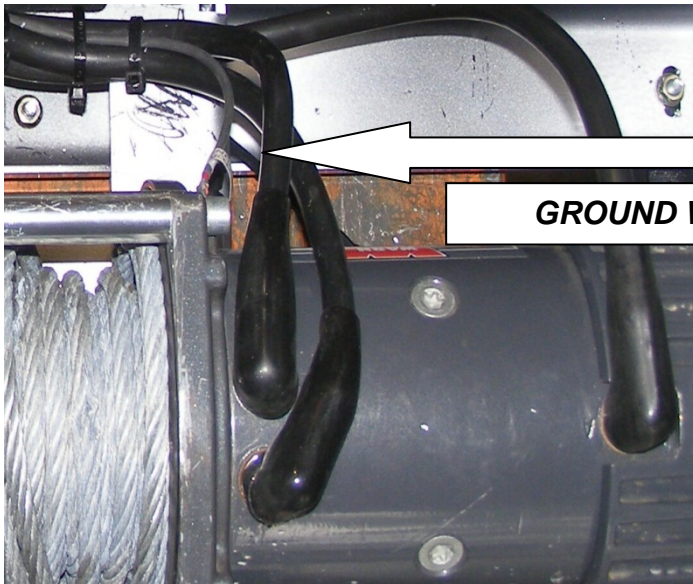

50. Fit ground wire under winch tie rod. (See Photo)

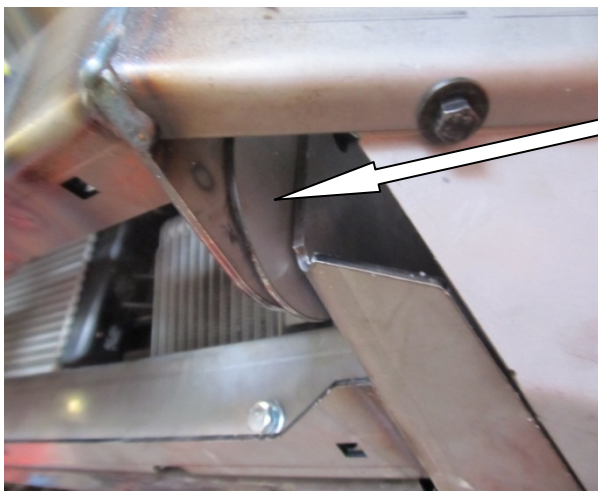

51. Before fitting the Bar, tape Packer to inside face of Chassis Mount (one per side at this stage).



52. With the help of a friend, lift bar in between impact mounting bracket and align slots on mounting bracket to the slots on the side of bar. Secure using M12 x 1.75 x 35 coarse pitch bolts, M12 spring, M12 flat washers and M12 flange nuts. ***Do not over tighten the bolts as to allow for bar adjustment.***

Note: If the Bar is positioned too much to one side, one of the packers from step 51 may have to be removed and added to the other side to centralise the Bar to the vehicle



53. Using body molding strip, fix to lower section of cut flare and trim to fit.
54. Adjust the position of the bar to under the flare gap which is 15, 20mm, and the parallelism between bar and vehicle, once the bar is in the desired position ***tighten the mounting bolts to their specified torque.***

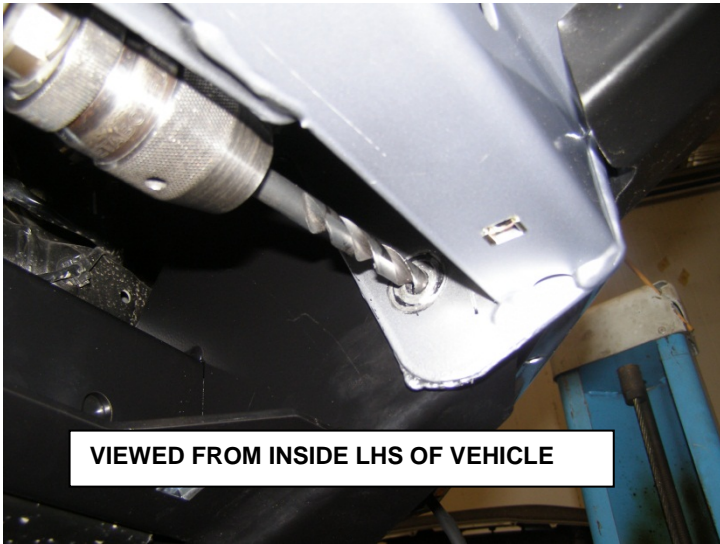

55. When all the six bolts have been tightened firmly, using the lower holes from inside the bar as a template, drill through the impact absorber bracket using a $\text{\O}10\text{mm}$ drill bit and fasten with a 10mm SEMS bolt and a 10mm flange nut to **specified torque**.

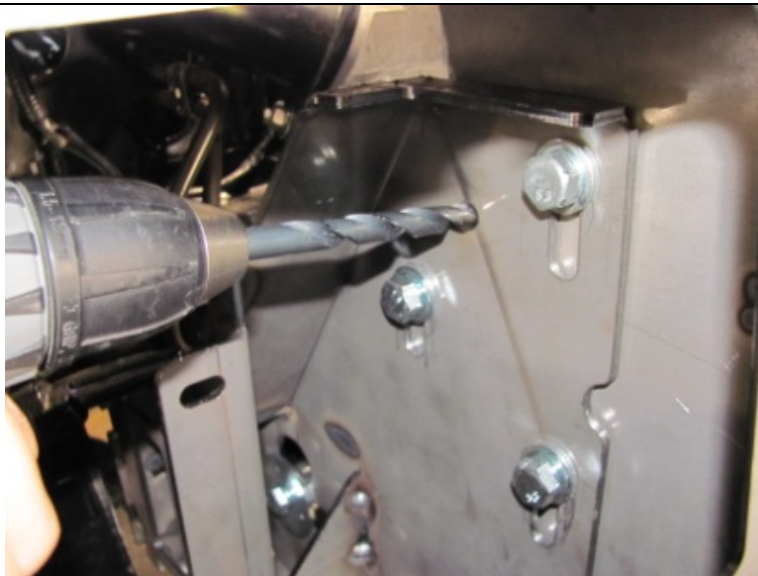
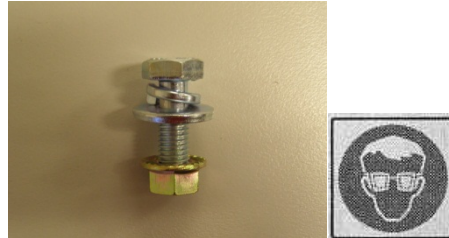

56. Now using the fog light opening for access, drill a $\text{\O}10\text{mm}$ hole in the top of the bars upright using the hole in the impact absorbers mounting blade as a template, the pin using M10 SEMS bolt and flange nut, tighten bolt to specified torque.

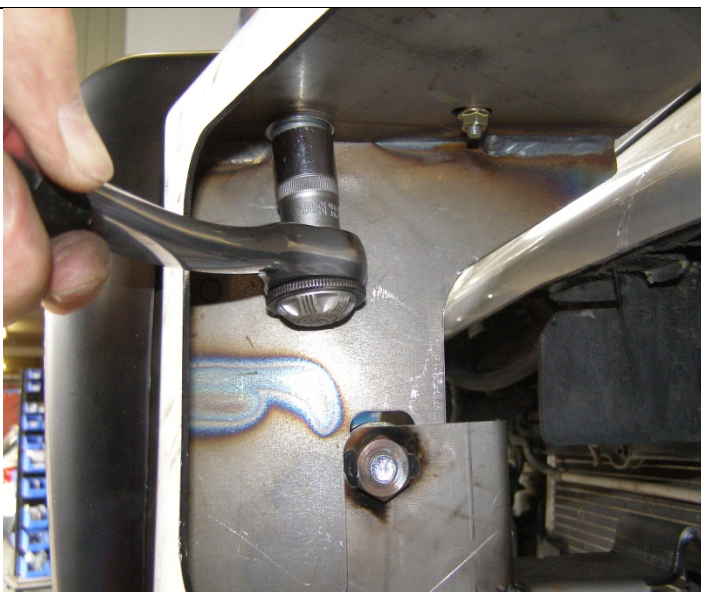

57. Press fit the Top Tube through the top of the Buffer Holes and secure using M12x40mm Bolts, Spring and Flat Washers.

NOTE:

Torque these M12 fasteners to 44Nm only (Critical)



58. Fit light insert into rear of bar using 4 screws, rubber washers and retainer clips. (**Do not over tighten**)



59. If optional fog lights are going to be fitted to bar, follow fitting instructions from fog light kit part no. 6821201 and wiring harness part.no.3500440

PHOTO DEPICTS FOG LIGHTS FITTED TO BAR

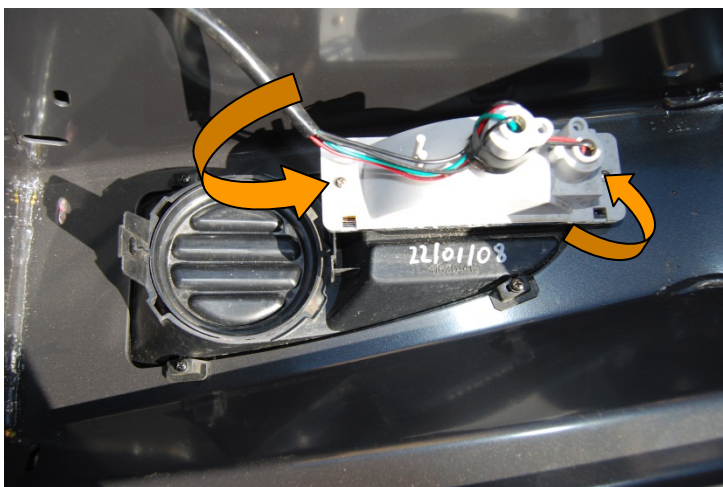

60. Install the turn signal into the rear of light insert using 2 self tapping screws 6 x 25mm pan head) supplied with the light insert fitting kit.

NOTE: - The indicators should be installed with the drain holes at the bottom and are marked LH / RHS. (Clearance lights outboard)

ARROWS INDICATES POSITION OF SCREWS

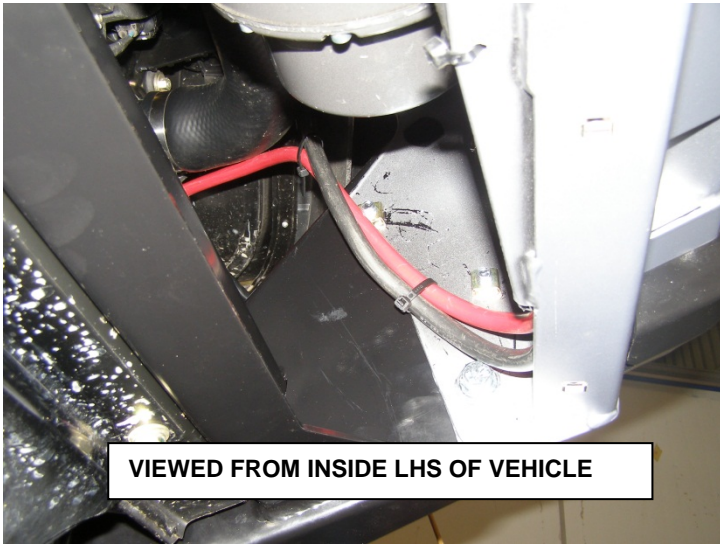

VIEWED FROM INSIDE LHS OF VEHICLE

61. When bar is secured to mounting bracket, connect winch cables to battery and cable tie cables together to clear of all moving parts, sharp edges and hot parts.

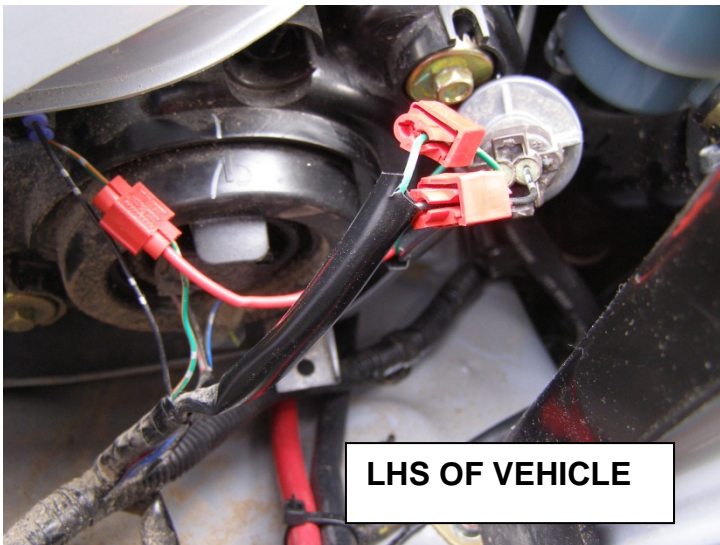

LHS OF VEHICLE

62. Pull indicator loom up into engine bay to scotch lok wiring onto vehicle indicator/clearance lamps

Summary of Wire Connections

FUNCTION	TURN SIGNAL HARNESS	VEHICLE PARK LAMP	
		RIGHT	LEFT
PARK LAMP	RED	GREEN/WHITE	GREEN/BROWN
		VEHICLE INDICATOR	
		RIGHT	LEFT
EARTH	BLACK	BLACK	BLACK
INDICATOR	GREEN	GREEN	GREEN

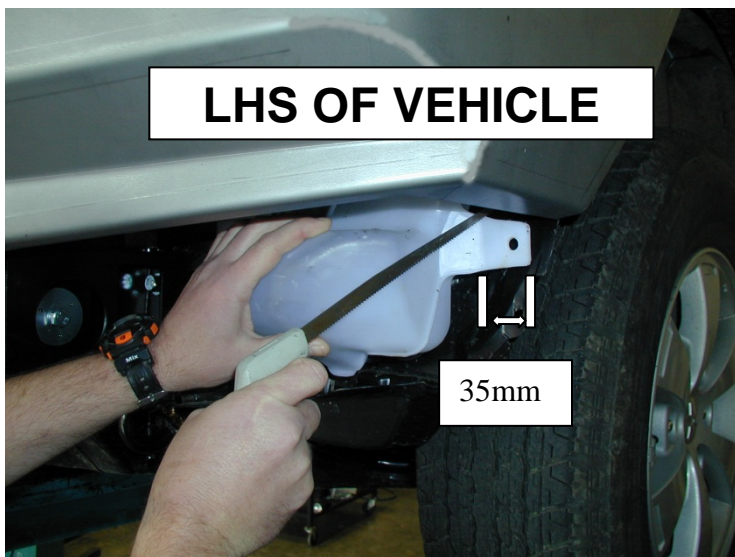

LHS OF VEHICLE

35mm

63. Before fitting under wing surround panels to bar, you must cut back washer bottle 35mm to give clearance of panel.

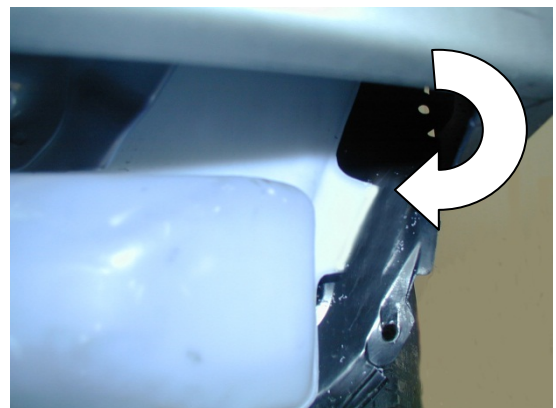

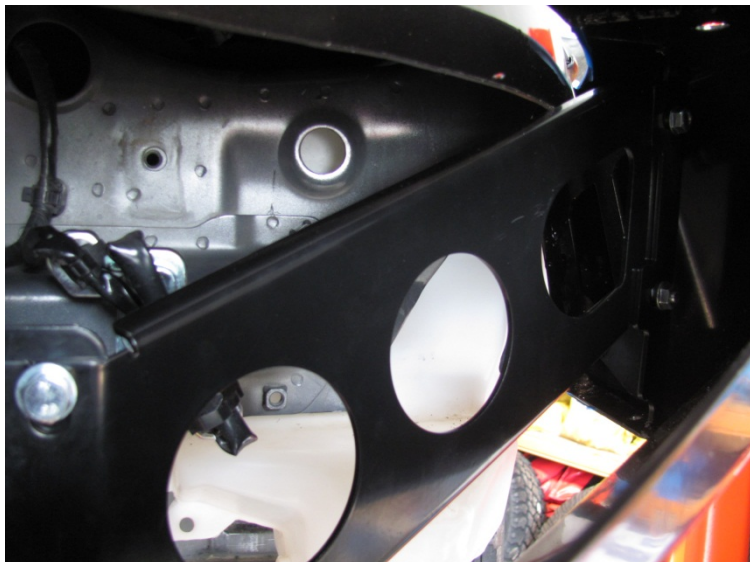

64. The next step is to fit wing braces to both sides of the bar using 8mm hardware.
65. Photo is of LHS of bar where brace fits to the mounting assembly.



66. Photo shows brace in position looking from the back of the bar.

Assembled off the vehicle for clear representation

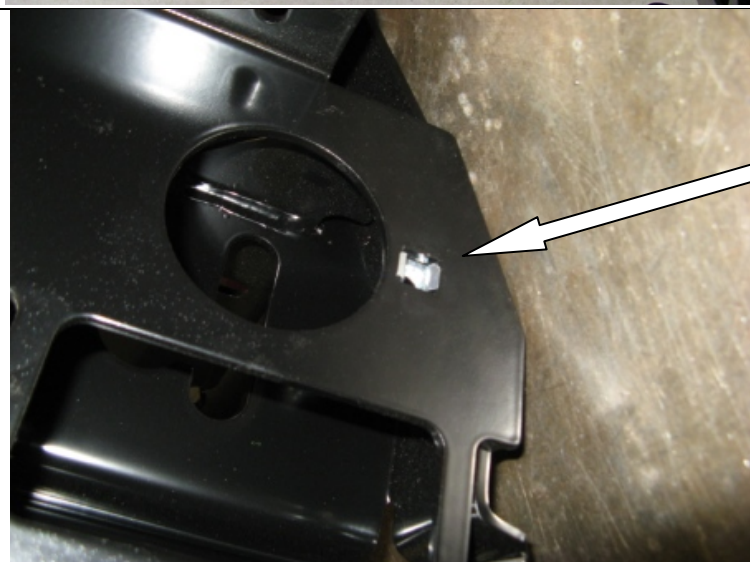

67. The next step is to fit the wing under panels, firstly M8 cage nuts must be fit to the mount assembly as shown.



68. Also M8 cage nuts must be fit two the adjustable wing under panel brackets as shown in the figure to the left.

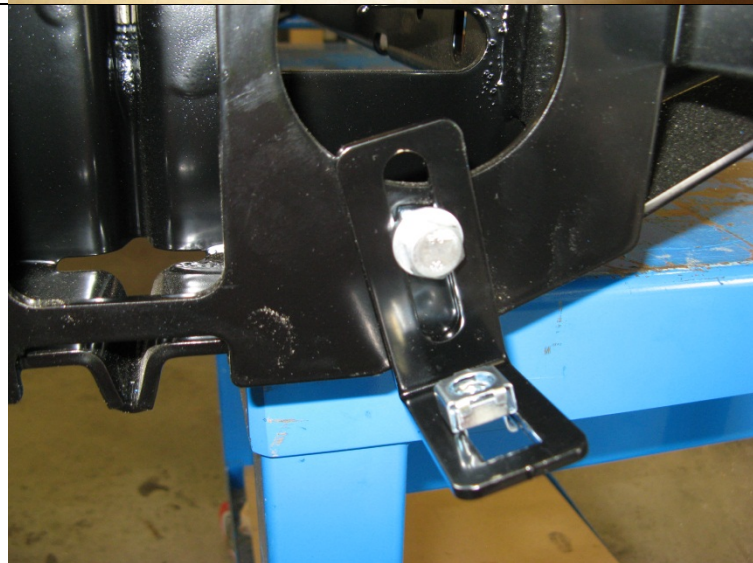

69. At this stage loosely fit the adjustable wing under panel bracket to the mount assembly.

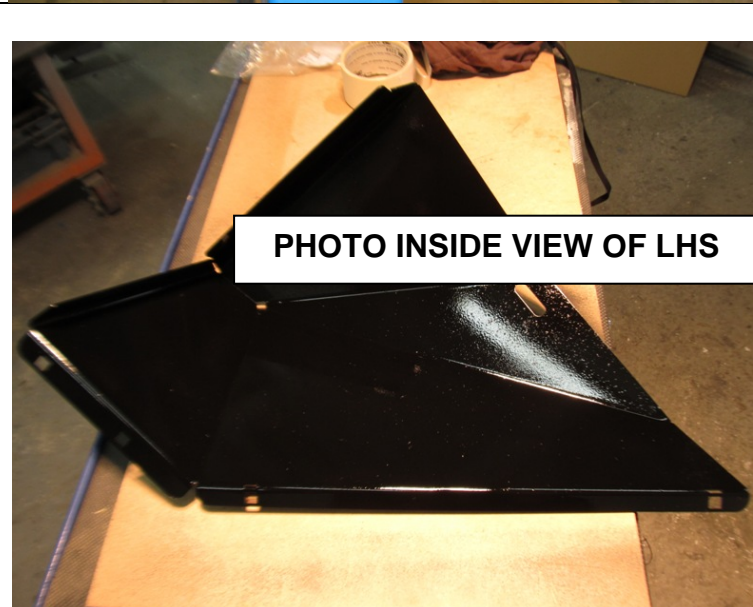

70. Fit M6 caged nuts into both L/RHS of under wing surround panels.
(4 per side)



71. Fit wing panels using black M6 hardware as per photo to both sides of vehicle. (4 per side)

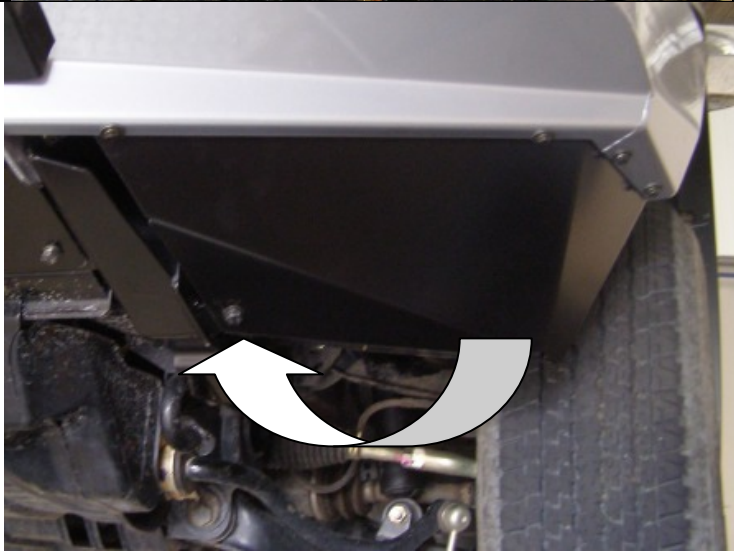

72. Now position the adjustable wing under panel bracket so that it aligns with the lower slot on the wing under panel and tighten the bracket in place.

73. Then securely bolt the lower wing under panel to the adjustable bracket.

Fit M8 black hardware as per arrow.



74. Remove plastic inner guards and cut along marked line.



Discard hatched area

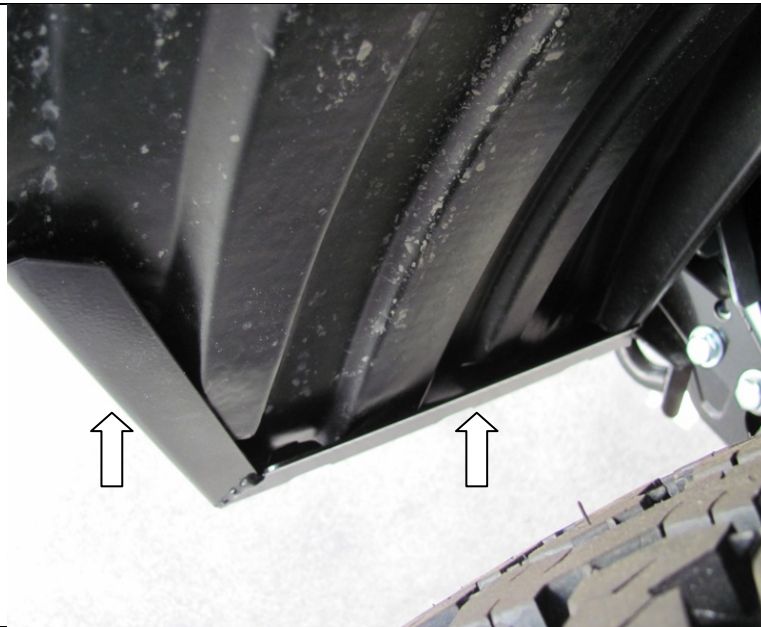

75. Refit the fender liner to the vehicle. Press the fender liner up to the wing under panels and scribe a line along the two edges shown.
76. Trim the liner using a sharp knife or small saw and tuck the liner within the under panel.

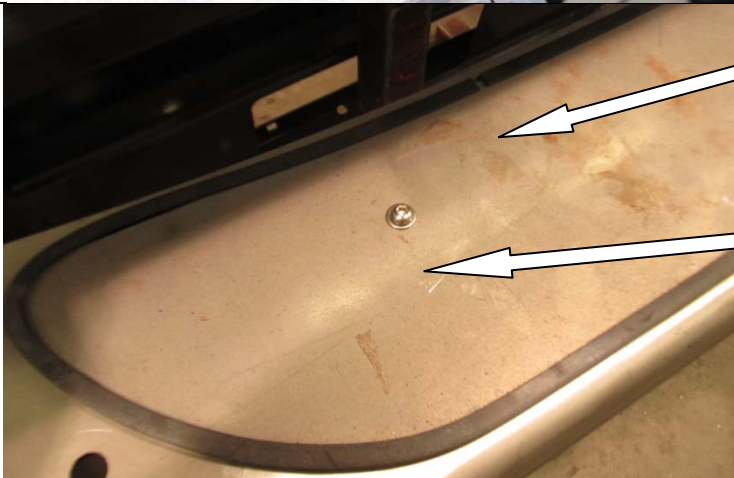

(If not fitting a Winch)

77. Starting at the centre of the back edge of the Panel Cover, fit rubber extrusion around the edge and trim edge to suit.
78. Fit Panel to the Bar using M6 Button Head S/S screws, making sure to place S/S Washer under screw head as shown and fasten using M6 Flange Nuts.



79. If you are not having a winch fitted to the bar, fit plastic grommets into the square holes and secure using black pan head screws to secure number plate to bar as per photo.



FITTED PRODUCT

